



## Storage drawer 15

FD 150 X



- Stainless steel finish
- 15 cm high front panel
- Push-to-open system
- Telescopic rails
- Anti-slip rubber mat

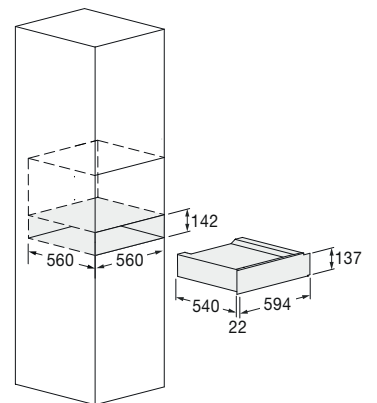

## Features

This product comes with the following accessories: telescopic rails and an anti-slip rubber mat. Moreover, it can be combined with Fulgor Milano's products from the 60 cm range



STAINLESS STEEL  
FD 150 X  
EAN 8019801031818

# DRAWERS

STORAGE DRAWER 15



FD 150 X		
Finish	Stainless Steel	
Type	Type: storage drawer	Anti-slip rubber bottom
Push-to-open door	•	
<b>DIMENSIONS</b>		
	Product (W x H x D) 594 x 137 x 562 mm	Built-In Cut Out (W x H x D) 560 x 142 x 560 mm