

# NikolaTesla Fit XL Raw

## Cooking

CONTROLS 9P+B slider touch control  
 VOLTAGE 220-240V  
 POWER LIMITATION 3,1kW - 4,5kW  
 NUMBER OF BRIDGE ZONES 2  
 FRONT LEFT COOKING ZONE OCTA 21x19,1 cm - 1,65/1,85 kW  
 RIGHT FRONT COOKING ZONE OCTA 21x19,1 cm - 1,65/1,85 kW  
 REAR LEFT COOKING ZONE OCTA 21x19,1 cm - 2,1/3 kW  
 REAR RIGHT COOKING ZONE OCTA 21x19,1 cm - 2,1/3 kW

## Generic Data

FINISHING Matt black glass  
 DIMENSIONS (CM)83x51,5x25  
 ENERGY CLASS A  
 CUT OUT 75x49 cm  
 TOTAL ABSORPTION 7,4 kW

## Extraction

AIRFLOW MIN DUCT-OUT 220m<sup>3</sup>/h  
 AIRFLOW MAX DUCT-OUT 500m<sup>3</sup>/h  
 AIRFLOW BOOST DUCT-OUT 620m<sup>3</sup>/h  
 AIRFLOW MIN FILTERING 135m<sup>3</sup>/h  
 AIRFLOW MAX FILTERING 420m<sup>3</sup>/h  
 AIRFLOW FILTERING 520m<sup>3</sup>/h  
 SUCTION SPEED 5,1m/s  
 NOISE LEVEL MIN-MAX ASPIRATION 43db(A) - 61db(A)  
 NOISE LEVEL MIN-MAX FILTER 44db(A) - 68db(A)  
 CONTROLS 4S+B Slider touch control  
 ABSORPTION 160 W

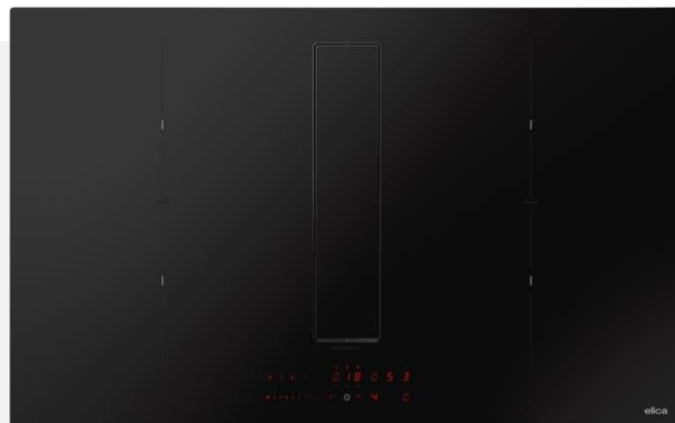

## NIKOLATESLA FIT XL 83 cm

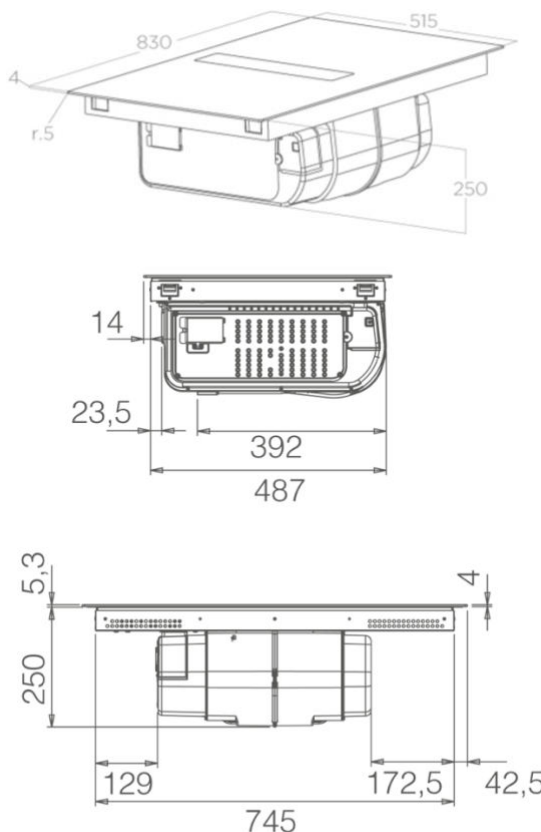
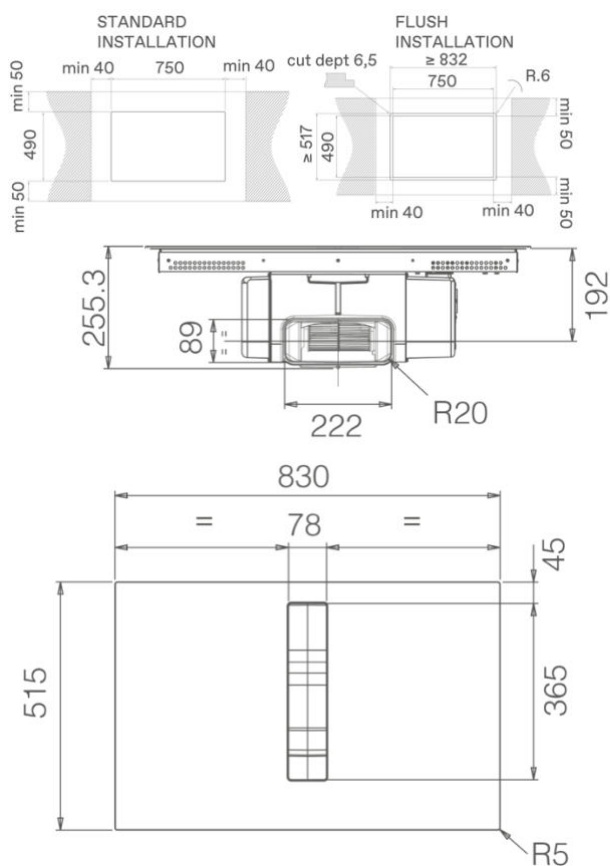

Recycling kit ( KIT0167757 ) Optional

